

DATASHEET

**WIRELESS SOUNDER INTERFACE MODULE +
CONVENTIONAL WALL SOUNDER VAD**

TW-MWSO-01 + CWS100-AV

The TW-MWSO-01 + CWS100-AV Taurus Wall Sounder VAD combines the Wireless Sounder Interface Module with the Conventional Wall Sounder VAD (each sold separately). The Taurus Wall Sounder VAD is a EN 54-3 (Type B) and EN 54-23 compliant visual/alarm device, equipped with 3 levels of volume adjustment, high output LED beacon, and 32 recognised tones which can be set via the control equipment or locally at the sounder. The wireless wall sounder VAD, once properly connected to a wireless system on a compatible loop, is fully controlled by the panel and benefits from an extensive range of intelligent control, test and monitoring functionality, including sounder synchronisation. Adaptive radio signal processing algorithms ensure the highest levels of life safety and reliability.



KEY FEATURES

- Bi-directional wireless communication
- 32 tones settings (primary and secondary for alert and evacuation), selectable via onboard dip switches
- On site adjustable volume settings
- Silent sounders setting for beacon only use
- 22 pairs of field channels
- Dual channel redundancy
- Long communication range (≈1 km in open air)
- 5 year battery life (including weekly test)
- Utilises standard low-cost lithium battery technology
- Easy scan & link programming option
- 3rd party approval
- 5 year product warranty

TECHNICAL SPECIFICATION

Operating frequency range	868 – 870 MHz
Max radiated power	14dBm (25mW)
Acoustic Frequency range	400-2900 Hz
Maximum acoustic Output	100 dB(A) ± 3
Visual Alarm Device (VAD) colour	White
Visual Alarm Device (VAD) frequency	0.5 Hz
VAD flash coverage	W-2.5-7 (EN 54-23)
IP rating	33C
Batteries	2x CR123A (3 V & 1.2 Ah)
Max humidity (non condensing)	95% RH
Operating Temperature	-10°C to +55°C
Weight (without batteries)	380 g
Dimensions (mm)	132 x 126 x 90

TECHNICAL INFORMATION

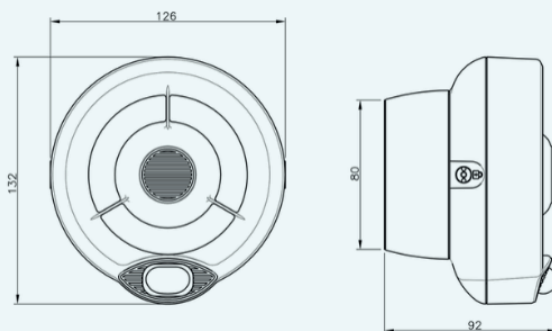

STANDARDS & APPROVALS

- EN 54-3: Fire alarm devices - Sounders
- EN 54-23: Fire alarm devices - Visual alarm devices
- EN 54-25: Components using radio links



DATASHEET

WIRELESS SOUNDER INTERFACE MODULE + CONVENTIONAL WALL SOUNDER VAD

TW-MWSO-01 + CWS100-AV

TAURUS
By ARGUS SECURITY



RELATED PRODUCT

The Taurus wireless system interface module (TW-MWSO-01) is designed for use with the Taurus range of modular wall sounders and beacons.

