

DATASHEET CONVENTIONAL WALL SOUNDER (WHITE)

CWS100(W)

The CWS100(W) Conventional Wall Sounder is equipped with 3 levels of volume adjustment and 32 recognised tones which can be set via the control equipment or locally at the sounder.



KEY FEATURES

- 5 year product warranty
- 3rd party approved
- 32 Tone Settings
- Two stage alarm capability
- Easy to install
- High sound output capability
- On site adjustable volume settings
- Microphone self test facility
- Robust with high reliability

TECHNICAL SPECIFICATION

Power supply voltage range	15Vdc – 40Vdc
Activated current load (High Vol.)	5-8 mA at 24 Vdc
Acoustic Frequency range	400-2900 Hz
Maximum acoustic Output	100 dB(A) @ 1m
Temperature range (no icing)	-25°C to +70°C
Unit weight (inc Back box)	290g
Max humidity (non condensing)	95% RH
IP rating	33C

TECHNICAL INFORMATION

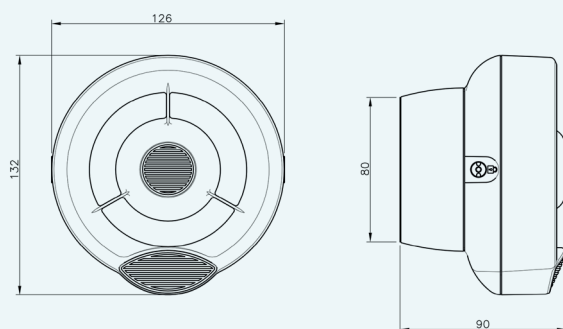

STANDARDS & APPROVALS

- EN 54-3: Fire alarm devices - Sounders

