

DATASHEET

DUCT DETECTION

DDH-VARIANTS

The Duct Smoke Detector provides early warning of smoke by continually sampling air movement within heating and ventilation ducts in industrial or commercial premises. The duct smoke detector provides switching facilities to shut down associated fans to prevent the spread of smoke into other areas.

DDH series has been designed to detect smoke in ventilation and combines an optical intelligent or conventional smoke detector, housing and sampling tube.

DDH series has been designed to allow optimum airflow through the optical smoke detector.

DDH series is recommended for installations in ducts with low airflow and will operate in air speed of 0.5m/s to 20m/s.



KEY FEATURES

- One-tube air sampling system
- Simple installation
- Filter for dusty environments
- Installer friendly cables connections
- Easy mounting of sampling tube
- 5 year product warranty
- Test hole positioned on cover
- Designed to comply with EN 54-27

TECHNICAL SPECIFICATION

Compatibility	Aurora, Vega & Altair smoke detectors & Sagittarius wireless smoke detector
Airflow speeds	0.5 m/s to 20 m/s
Dimensions	279mm x 165mm x 83mm (plus 20mm pipe entry)
Unit weight	660g
Operating Temperature (no icing)	-10°C to +55°C
Max humidity (non condensing)	95% RH

TECHNICAL INFORMATION

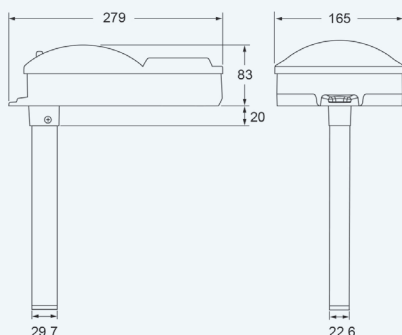

Argus Security S.r.l.

Via del Canneto, 14 – Località Vignano Z.I.
Valle delle Noghère
34015 Muggia (TS) Italy

T: +39-040.23.96.41
E: info@argussecurity.it
www.argussecurity.it

DATASHEET

DUCT DETECTION

DDH-VARIANTS

ORDER CODE

DDH-LAB	Duct Detector Housing with Altair Base
DDH-UB	Duct Detector Housing with Standard Base
DDH-UBR	Duct Detector Housing with Resistor Base
DDH-BLR	Duct Detector Housing with Relay Base
DDH-ST0.6	0.6 m Sampling Tube
DDH-ST1.5	1.5 m Sampling Tube, c/w rubber gasket
DDH-ST2.8	2.8 m Sampling Tube, c/w rubber gasket
DDH-BR	Mounting Bracket for circular or insulated flat ducts, with sealing sleeve and rubber gasket
DDH-C	Waterproof Cover for Outdoor or Special Environment Applications, 273x122x460mm
DDH204	Spare Gasket